

MODULAR RANGE

Build it your way!



 **AES**
GLOBAL

WWW.AESGLOBALONLINE.COM



=



MOD-1X1

+



MOD-PRIME6-1B-4GE (EU)

MOD-PRIME6-1B-4GSA (AU+NZ)

MOD-PRIME6-1B-4GA (USA+CAD)

Build it your way!



=



MOD-1X2

+



+



MOD-PRIME-5B

MOD-PRIME6-4GE (EU)

MOD-PRIME6-4GSA (AU+NZ)

MOD-PRIME6-4GA (USA+CAD)

Cellcomprime

Advanced GSM Intercom



Set automatic gate open & close times.



Do-not-disturb watershed time.



User history log to your phone.



Illuminated call button and keypad.



Add keypad codes by App.



Issue time restricted codes.



High gain antenna as standard!



2x Relays

App Screens

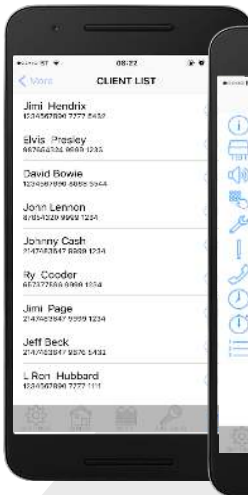

Create a list of all your installs for later editing or diagnostics

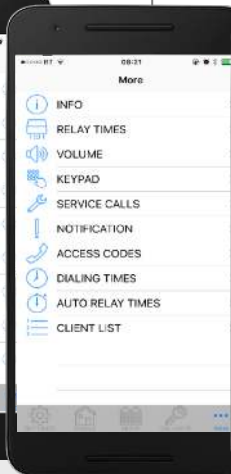

Complete menu of all parameters for editing by app

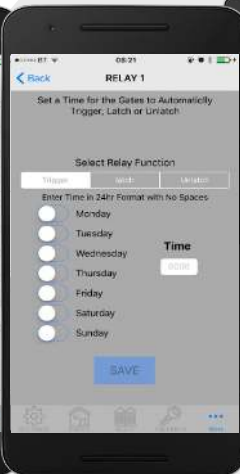

Program auto opening and closing times

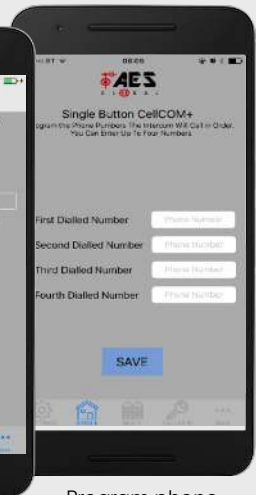

Program phone numbers easily!

*App images for illustrative purposes only.

GSM SINGLE BUTTON MODULE RANGE

GSM Compulsory Module Options



MOD-PRIME6-1B-4GE (EU)
MOD-PRIME6-1B-4GSA (AU+NZ)
MOD-PRIME6-1B-4GA (USA+CAD)

MOD-PRIME6-4GE (EU)
MOD-PRIME6-4GSA (AU+NZ)
MOD-PRIME6-4GA (USA+CAD)

Accessory Modules Options

MOD-PRIME-1B



Optional Trades
Button

MOD-INFO



Illuminated
information window

MOD-PRIME-KP



Illuminated
keypad

MOD-PRIME-PX



Prox

MOD-PRIME-PX-KP



Combined Prox
and keypad

MOD-PRIME-VIG



Module for Vigik
cut out

MOD-DDA-LOOP



Hearing Loop

GSM SINGLE BUTTON MODULE RANGE

GSM SINGLE BUTTON EXAMPLES



BACK BOX OPTIONS



MOD-1x1

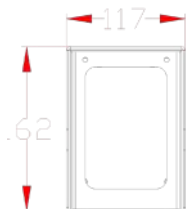

MOD-1x3



MOD-2x2



MOD-1x2

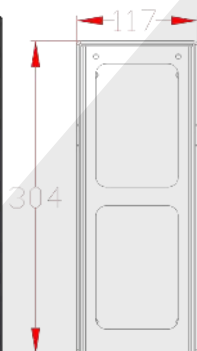



Cellcomprime

Advanced GSM Multi-button Intercom



Set automatic gate open & close times.



Do-not-disturb watershed time.



User history log to your phone.



Illuminated call button and keypad.



Add keypad codes by App.



Issue time restricted codes.



High gain antenna as standard!



2x Relays

App Screens

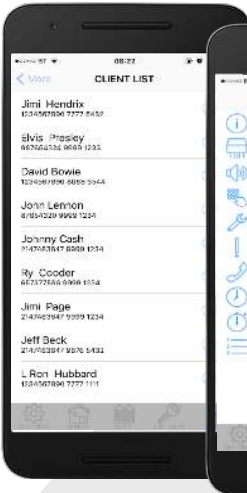

Create a list of all your installs for later editing or diagnostics

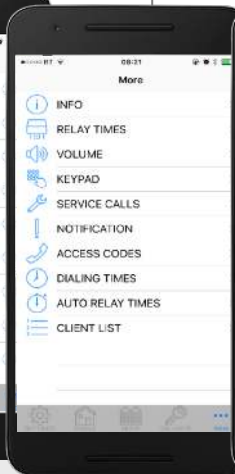

Complete menu of all parameters for editing by app

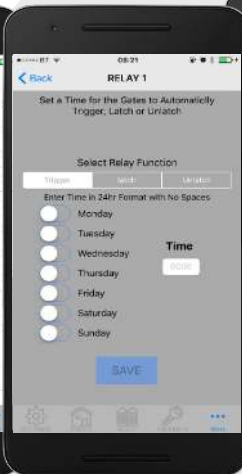

Program auto opening and closing times



Program phone numbers easily!

MULTI-BUTTON MODULE RANGE

GSM Compulsory Module Options



MOD-PRIME6-1B-4GE (EU)
MOD-PRIME6-1B-4GSA (AU+NZ)
MOD-PRIME6-1B-4GA (USA+CAD)

MOD-PRIME6-4GE (EU)
MOD-PRIME6-4GSA (AU+NZ)
MOD-PRIME6-4GA (USA+CAD)

Accessory Modules Options

MOD-PRIME-1B



1 Button Module

MOD-PRIME-2B



2 Button Module

MOD-PRIME-3B



3 Button Module

MOD-PRIME-4B



4 Button Module

MOD-PRIME-5B



5 Button Module

MOD-INFO



Illuminated
information
window

MOD-PRIME-KP



Illuminated
keypad

MOD-PRIME-PX-KP



Combined
Prox and
keypad

MOD-PRIME-PX



Prox

MOD-PRIME-VIG



Module for
Vigik cut out

MOD-DDA-LOOP



Hearing Loop

GSM MULTI BUTTON MODULE RANGE

GSM MULTI BUTTON EXAMPLES

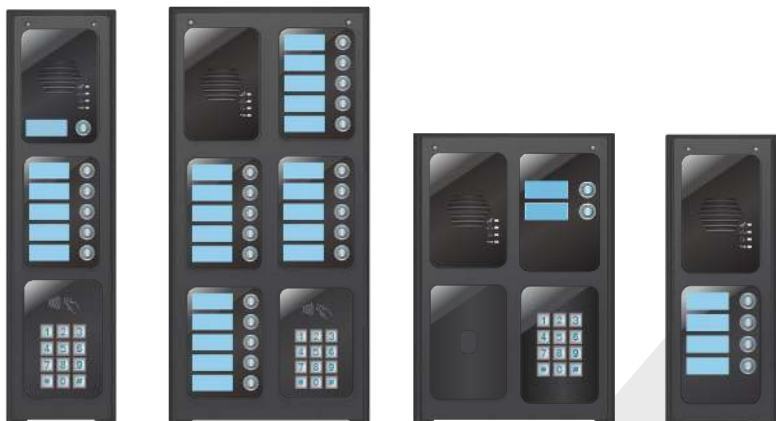

BACK BOX OPTIONS



Pre-assembled Modular Units

MULTI-BUTTON MODULAR RANGE (NON-KEYPAD)

4GE (EU)
4GSA (AU+NZ)
4GA (USA+CAD)

MOD-2B/4GE



2 Button
Assembled Unit

MOD-3B/4GE



3 Button
Assembled Unit

MOD-4B/4GE



4 Button
Assembled Unit

MOD-5B/4GE



5 Button
Assembled Unit

MOD-6B/4GE



6 Button
Assembled Unit

MOD-7B/4GE



7 Button
Assembled Unit

MOD-8B/4GE



8 Button
Assembled Unit

MOD-9B/4GE



9 Button
Assembled Unit

MOD-10B/4GE



10 Button
Assembled Unit

Pre-assembled Modular Units

MULTI-BUTTON MODULAR RANGE (WITH KEYPAD)

4GE (EU)
4GSA (AU+NZ)
4GA (USA+CAD)

MOD-6B-KP/4GE



2 Button
Assembled Unit

MOD-3B-KP/4GE



3 Button
Assembled Unit

MOD-4B-KP/4GE



4 Button
Assembled Unit

MOD-5B-KP/4GE



5 Button
Assembled Unit

MOD-6B-KP/4GE



6 Button
Assembled Unit

MOD-7B-KP/4GE



7 Button
Assembled Unit

MOD-8B-KP/4GE



8 Button
Assembled Unit

MOD-9B-KP/4GE



9 Button
Assembled Unit

MOD-10B-KP/4GE



10 Button
Assembled Unit



Multicom lite

Multi Family Intercom



- Multi apartment / multi resident wireless cellular intercom.
- 4G LTE capable.
- Up to 30 family using illuminated directory screen, or up to 100 family direct dialing from the keypad.
- Programmable remotely by free APP.
- Store visitor codes by APP.
- Prox card access options available

Free programming app



*App images for illustrative purposes only.

MULTI-COM LITE MODULE RANGE

Multi-Com Lite Compulsory Module Options

MOD-INFO



Illuminated
information
window



MOD-PRIME6-4GE (EU)
MOD-PRIME6-4GSA (AU+NZ)
MOD-PRIME6-4GA (USA+CAD)



4G GSM
Module
-HD Voice
-Pentaband LTE
-3G / 2G fallback
(dependant on availability)
-DDA LEDs



MOD-MULTI-PX-KP



Combined
Prox and
keypad



MOD-MULTI-KP



Illuminated
keypad

Accessory Modules Options

MOD-PRIME-PX



Prox

MOD-PRIME-VIG



Module for
Vigik cut out

MOD-DDA-LOOP



Hearing
Loop

MULTI-COM LITE MODULE RANGE

MULTI-COM LITE EXAMPLES



BACK BOX OPTIONS



MOD-2x2



MOD-1x3

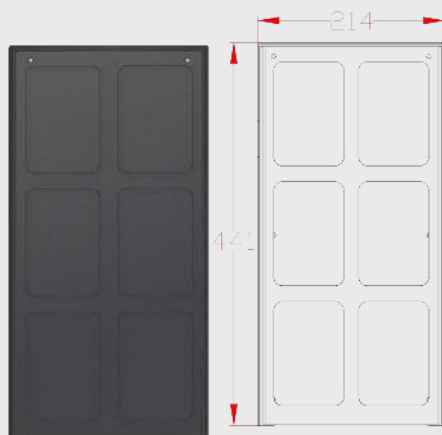

MOD-2x3

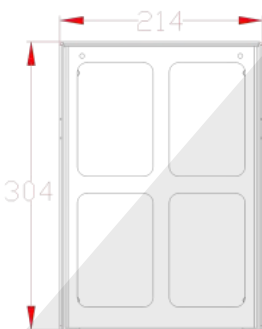



Multicom Classic

Multi Family Intercom



- Calls up to 500 families from a single SIM card.
- Visitors can scroll for residents, or enter apartment number to call.
- Dials up to 3 phone numbers per family on roll over.
- 4G Ready.
- HD voice with VOLTE*.
- Programmable locally by USB PC link with free software, or remotely with free Android and Iphone apps.
- Proximity card version available.
- Built in time clock for auto opening and closing of gates, barriers or doors in busy periods or for day time operation.
- 2 relays.

Free programming app



*App images for illustrative purposes only.

MULTI-COM CLASSIC MODULE RANGE

Multi-Com Classic Compulsory Module Options

MOD-CLASSIC



Illuminated information window with Scroll Buttons



MOD-PRIME6-4GE (EU)
MOD-PRIME6-4GSA (AU+NZ)
MOD-PRIME6-4GA (USA+CAD)



4G GSM Module
-HD Voice
-Pentaband LTE
-3G / 2G fallback (dependant on availability)
-DDA LEDs



MOD-MULTI-PX-KP



Combined Prox and keypad



MOD-MULTI-KP



Illuminated keypad

Accessory Modules Options

MOD-PRIME-PX



Prox

MOD-PRIME-VIG



Module for Vigik cut out

MOD-DDA-LOOP



Hearing Loop

MULTI-COM CLASSIC MODULE RANGE

MULTI-COM CLASSIC EXAMPLES



BACK BOX OPTIONS



MOD-2x2



MOD-1x3

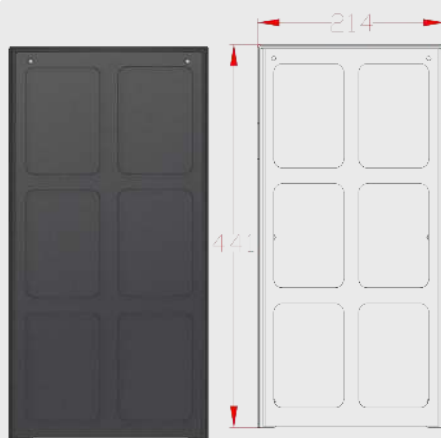

MOD-2x3

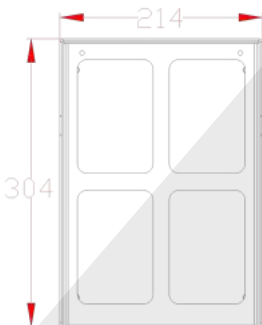



100

D.E.C.T 703

Multi-Button Intercom

- Digital D.E.C.T wireless intercom system for flats, apartments or shared gate entrances.
- Up to 4 call buttons, each button calling a different handset.
- Working range of 100 metres through concrete (up to 500 metres open field).
- 1 handset per property or apartment.
- Simple setup and install.
- Keypad option for coded access.
- Built in voicemail feature for missed callers, user can listen to messages on handset.



Technical Details

Power Supply	24v ac/dc (24v dc adaptor included).	Cable Between Speech Unit & Transmitter	4 metre screened CAT5 included.
Current Draw	50mA standby, 1 amp peak.	Max Cable Length	8 metres max.
Relay Outputs	2	Cable Cores	2 x SPK, 2 x MIC, 2 x button, 2 x relay, 2 x power.
Relay Time	Adjustable, 1,3,5,9 secs.	Speech Unit IP Rating	IP55.
Relay Load	Max 2 amps, 24v ac.	Transmitter IP Rating	IP65.
Technology Type	Digital DECT.	Manufacturer Warranty	2 years* (RTB).
Handsets per System	4	Keypad Programming	On the keypad.
Range	Practical working range of 100 metres. 500 metres open field conditions.	Keypad Codes	1200 codes total.

703 MODULE RANGE

703 Compulsory Module Options

MOD-CP



Accessory Modules Options

MOD-PRIME-2B



2 Button Module

MOD-PRIME-3B



3 Button Module

MOD-PRIME-4B



4 Button Module

MOD-ASSM-PX-KP



Combined Prox and keypad

MOD-ASSM-KP



Illuminated keypad

MOD-PRIME-VIG



Module for Vigik cut out

BACK BOX OPTIONS



MOD-2x2



MOD-1x2



MOD-1x3



DECT 703 Compulsory items

Up to 4 call buttons, each button calling a different handset.



703-TX2-V2

For a 2 button kit.
2 audio handsets and transmitter.



703-HF-TX2-V2

For a 2 button kit.
2 wall/desk mount audio monitors and transmitter.



703-TX3-V2

For a 3 button kit.
3 audio handsets and transmitter.



703-HF-TX3-V2

For a 3 button kit.
3 wall/desk mount audio monitors and transmitter.



703-TX4-V2

For a 4 button kit.
4 audio handsets and transmitter.



703-HF-TX4-V2

For a 4 button kit.
4 wall/desk mount audio monitors and transmitter.

D.E.C.T 703

Multi-Button Intercom

Pre-assembled Modular Units

WIRELESS MULTI-BUTTON 703 MODULAR UNITS

703-2B



2 Button
Assembled Unit

703-3B



3 Button
Assembled Unit

703-4B



4 Button
Assembled Unit

703-2B-KP



2 Button
Assembled Unit

703-3B-KP



3 Button
Assembled Unit

703-4B-KP



4 Button
Assembled Unit



D.E.C.T 603

Wireless audio Intercom System



- Up to 500 meters open field range!
- Working range of 200 meters through 1 exterior concrete, brick or stone wall.
- Up to 4 handsets / indoor units per system.
- Built in voicemail feature to record missed callers at your door or gate (playback from handset).
- Intercall between handsets.
- 2 year warranty.



Technical Details			
Outdoor Unit		Indoor Unit	
Relays	2	Power Supply	Charging Base = 5v dc. Wall Unit = 12v dc.
Construction	Marine Stainless & Powder Coated Aluminium	Volume Adjust	Yes
Keypad Relays	3	Voicemail Capacity	16
Power Supply	24v ac/dc (24v 2A dc adaptor included)	Calling Between Handsets	Yes
Current Consumption	65mA Standby, 400mA Calling	Tag/Card Type	125kHz fixed digit code card, passive type
		Tag/Card Quantity	200 permanent, 20 time restricted, 30 temporary users

SLIM Compulsory Module Options

MOD-603



Accessory Modules Options

MOD-ASSM-PX-KP



Combined Prox
and keypad

MOD-ASSM-KP



Illuminated
keypad

MOD-PRIME-VIG



Module for Vigik
cut out

BACK BOX OPTIONS



MOD-1x1

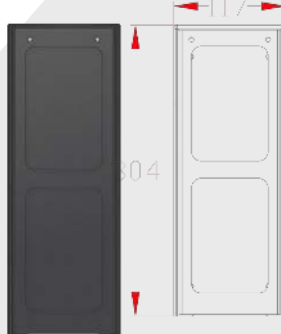
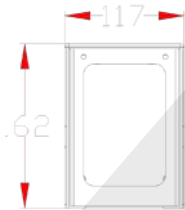

MOD-1x2



MOD-1x3



DECT 603 Compulsory items



603-TX-V2

1 audio handset and transmitter.



603-HF-TX

1 wall/desk mount audio monitor and transmitter.

Optional Extra items



603-EH

Add up to 3 additional audio handsets. (4 in total)



603-HF-EH

Add up to 3 additional Handsfree Wall/desk audio handsets. (4 in total)



603-WIFIA

Range boosting antenna which can be added to transmitter at gate and also optionally to the handsfree monitor type. One antenna can boost range by 30%. Comes with 2 metre antenna cable (RG174 with SMA male connector).

D.E.C.T 705

Wireless Video Intercom



- Wireless video intercom system for gates.
- Longest range Rf video intercom in the world, working range 200 metres (450m open field).
- Unique technology combining 2.4GHz digital & DECT 1.88GHz digital signals.
- Colour camera with infrared night vision capability.
- Long range antenna as standard.
- Gate / Door release relay built in.
- Optional keypad for access control.
- Voicemail feature built in.

Digital Wireless Signal
for Clear Voice 



Antenna



Video Handset



Handsfree
Wall/Desk Mount
Available

Technical Details

Power Supply	24v dc (24v dc 2A adaptor included)	Handset Battery	Lithium Ion mobile phone battery
Current Consumption	50mA standby, 1Amp calling	Night Vision	Yes, by infrared illumination
Relay Outputs	1	Battery Life	24 hours between charges
Relay Type	N/O & N/C contacts	Charging Voltage	5v dc (5v dc adaptor included)
Relay Time	Fixed 4 seconds	Keypad Option	Yes
Relay Load	2A 24v AC max	Keypad Relays	3
IP Rating	IP55	Keypad Codes	1200* Across 3 separate relays*
Camera	Colour, 80 degree viewing angle		

705 Compulsory Module Options

MOD-705



Accessory Modules Options

MOD-ASSM-PX-KP



Combined Prox
and keypad

MOD-ASSM-KP



Illuminated
keypad

MOD-PRIME-VIG



Module for Vigik
cut out

BACK BOX OPTIONS



MOD-1x1

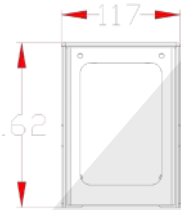

MOD-1x2



MOD-1x3



DECT 705 Compulsory items

For the 705 video handset options:



705-VH

705 Portable Handset



705-HF-VH

705 Wall/desk monitor



705-ANT

705 long range video Antenna

Optional Extra items



705-EH

Add up to 3 additional audio handsets to any 705 kit as additional slave handsets.



705-HF-EH

Add up to 3 additional Handsfree Wall/desk audio handsets.



705-AC5

Antenna extension cable. 2x5 metres long to extend antenna height.

StylusCom

Smart Intercom System



- Combines access control and CCTV in one system.
- Super long range over CAT 5 (300 metres).
- Motion detection recording (from one device).
- SD card records stills of visitors/missed callers.
- Option to connect external camera to speech panel for certain applications.
- Easy to wire monitor with wall mounted connection panel.
- 24V 2A dc adaptor included.



Black Dome camera option.



Styluscom Monitor featuring a 4.3 inch screen.



Black Bullet camera option.

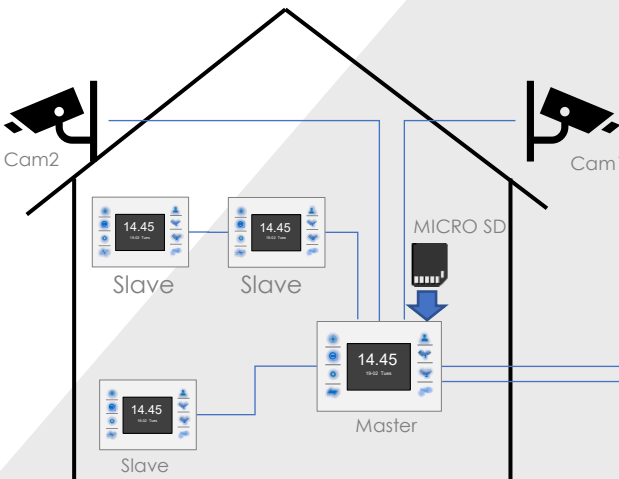

Up to 2 gates and 2 CCTV cameras connected to a maximum of 4 monitors.

Gate 2



Gate 1

Styluscom Compulsory Module Options

MOD-STYUSCOM



Accessory Modules Options

MOD-ASSM-PX-KP



Combined Prox
and keypad

MOD-ASSM-KP



Illuminated
keypad

MOD-PRIME-VIG



Module for Vigik
cut out

BACK BOX OPTIONS



MOD-1x1

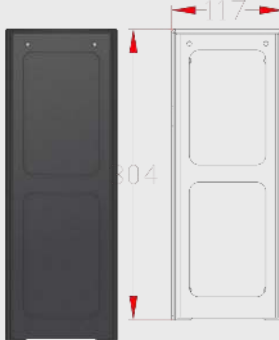
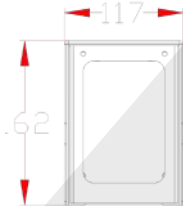

MOD-1x2



MOD-1x3



STYLUSCOM Compulsory item

Stylus-4.3



STYLUSCOM Monitor

Optional Extra items

Stylus-4.3



- Additional monitor for larger homes. (Add up to 3 monitors. 4 in total)
- Sleek design, featuring a gloss white screen trim.
- Wall mountable, hands free design.
- Touch sensitive buttons.
- Volume control.
- 4,3 inch screen.
- Power supply included.

Stylus-Dome



- Black Dome camera.
- Day/Night Vision with a 10 metre night range.
- 700 TVL.
- 4mm fixed lens.
- Power supply not included.

Stylus-Bullet



- Black Bullet camera.
- Day/Night Vision with a 10 metre night range.
- 700 TVL.
- 4mm fixed lens.
- Power supply not included.



SLIM

Wired Intercom System

- Wired audio intercom system.
- Up to 4 handsets per system.
- Curved profile stylish handset available in black or white.
- 150m typical cabled range using twisted pair cables.
- 24V dc 2A power supply included. (Handsets 12v dc)



Black or White **corded** handset option.



Black or White **handsfree** handset option.

Technical Details	
Power	24v dc (24c dc 2A included)
Working Distance	150m on 24AWG CAT5 cable
Weather Rating	IP55
Wiring	3 Wire or 5 wire option
Max Handsets	4
Relay Type	N/O momentary 4 second pulse

Indoor Speech Unit

Outdoor Speech Unit

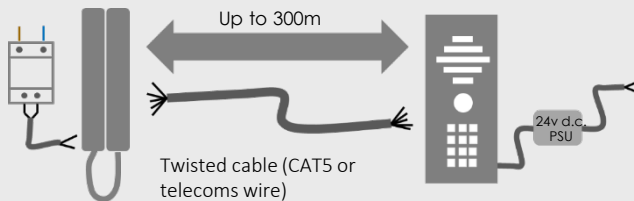

SLIM Compulsory Module Options

MOD-SLIM



Accessory Modules Options

MOD-ASSM-PX-KP



Combined Prox
and keypad

MOD-ASSM-KP



Illuminated
keypad

MOD-PRIME-VIG



Module for Vigik
cut out

BACK BOX OPTIONS



MOD-1x1

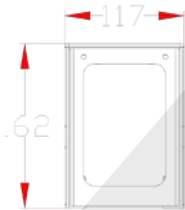

MOD-1x2



MOD-1x3



SLIM Compulsory items

For a SLIM kit with **CORDED** handset:

Black corded handset



White corded handset



For a SLIM kit with **HANDSFREE** handset:

Black handsfree handset



White handsfree handset



Optional Extra items

Add up to 3 extra handsets to any kit (total 4 per system) for larger homes or premises.



SLIM-HF-EH-B



SLIM-CL-EH-B



SLIM-HF-EH-W



SLIM-CL-EH-W

WiFi Predator 2

Wi-Fi / LAN Video Intercom



Long Range Antenna
(up to 60m working range depending on
router type and location)!



Existing Wi-Fi Hub

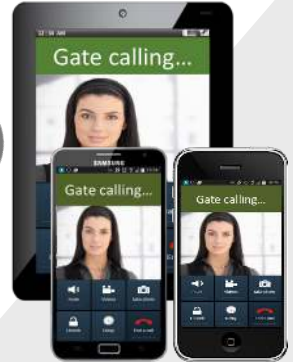

- Simple setup by mobile phone.
- Connect to the intercom directly through your phone's Wi-Fi, enter the pass code for the home hub Wi-Fi and the device is connected.
- View the gate/door and open any time with monitoring mode.
- Full duplex speech.
- 2 relay output.
- Latching outputs for hold open.
- CAT5 terminal port for easy hard wire option.
- Upgraded camera with IR cut filter for better colour by day and IR night vision by night.
- Stores images of the last 32 missed callers on your phone.
- Can work with most market standard outdoor Wi-Fi repeaters for extended range.*

*Requires a min. signal level of 25. For best reliability in long distances using a LAN cable is advised.



TAB-10

Wall mount touch screen monitor
(1280x800 Resolution), compatible
with the Predator system.

WiFi Predator 2 Compulsory Module Options

MOD-PRED2



Accessory Modules Options

MOD-ASSM-PX-KP



Combined Prox
and keypad

MOD-ASSM-KP



Illuminated
keypad

MOD-PRIME-VIG



Module for Vigik
cut out

BACK BOX OPTIONS



MOD-1x1

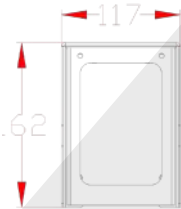

MOD-1x2



MOD-1x3



WiFi Predator 2 Compulsory items

WIFIA-2



WiFi Antenna
2.4Ghz Wifi Antenna
with 2m Lead.



WIFIA-10



WiFi Antenna
2.4Ghz Wifi Antenna
with 10m Lead.

Optional Extra item



- Wall mount touch screen monitor (1280x800 Resolution), compatible with the Predator system.
- 10.1 inch screen IPS LCD android screen with RJ-45 interface USB port.
- WiFi connectable.
- POE supplied (12V DC can be purchased separately)
- Complete with both wall mount bracket and desk stand.
- Android OS (4.4.2) with Predator PRO app pre-loaded.
- A64 Quad Core 1.6 ghz.

4G Predator 2

4 G Video Intercom



- 4G Modular version of the fastest growing AES product, the Predator Video Intercom.
- Connects to 4G network with 4G compatible SIM (Included*).
- No need for Wi-Fi connectivity. Totally independent from home network.
- Easy plug and play setup with same app as Wi-Fi version.
- Simply connect both devices together via Ethernet cable (supplied), connect power and log on with provided credentials.
- Complete with 24V dc PSU (for intercom), and POE adaptor (for modem).
- 100 calls per ½ GB of data (based on 30 second calls).

*System will be preloaded to work with the network of the SIM provided. Registration is required to set up payment plan before the SIM will become active. You have the option to provide your own SIM, this will incur additional setup that can be advised by our technical team directly to the installer.)



TAB-10

Wall mount touch screen monitor (1280x800 Resolution), compatible with the Predator system.

4G Predator 2 Compulsory Module Options

MOD-PRED2



Accessory Modules Options

MOD-ASSM-PX-KP



Combined Prox
and keypad

MOD-ASSM-KP



Illuminated
keypad

MOD-PRIME-VIG



Module for Vigik
cut out

BACK BOX OPTIONS



MOD-1x1

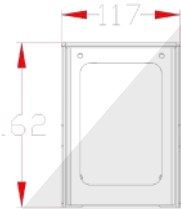

MOD-1x2



MOD-1x3



4G Predator 2 Compulsory item

4GE/M (EU)
4GSA/M (AU+NZ)
4GA/M (USA+CAD)



4G Modem

Optional Extra item



- Wall mount touch screen monitor (1280x800 Resolution), compatible with the Predator system.
- 10.1 inch screen IPS LCD android screen with RJ-45 interface USB port.
- WiFi connectable.
- POE supplied (12V DC can be purchased separately)
- Complete with both wall mount bracket and desk stand.
- Android OS (4.4.2) with Predator PRO app pre-loaded.
- A64 Quad Core 1.6 ghz.





AES GLOBAL LTD
Unit 4C, Kilcronagh Business Park,
Cookstown, Co Tyrone, United Kingdom,
BT80 9HJ

www.aesglobalonline.com
sales@aesglobalonline.com